

# SAFETY CHECKLIST

## Miniature circuit breakers (MCBs)/Residual current operated circuit-breakers without integral overcurrent protection (RCCBs)/Residual current operated circuit breaker with integral overcurrent protection (RCBOs)

This Checklist outlines simple measures to help identify counterfeit and non-conforming products.

Non-conforming products present significant risks to people and property and carry serious consequences for the distributor and installer of such products. Non-conforming products will not ensure protection against fire or electrocution, potentially resulting in lethal consequences. **Choose your electrical circuit protection products with care.**

The main function of a miniature circuit breaker (MCB) is overcurrent protection. It must interrupt electrical current in the case of a short circuit or an overload current flowing in an electrical circuit.

The main function of a residual current operated circuit-breaker without overcurrent protection (RCCB) is that it must interrupt electrical current in the case of a leakage current to earth.

The main function of a residual current operated circuit breaker with integral overcurrent protection (RCBO) is protection against overcurrent and earth leakage. It must interrupt electrical current in the case of:

1. Short circuit or overload current in an electrical circuit.  
or
2. A leakage current to earth.

Performance criteria is defined by the appropriate product standard e.g. BS EN 60898, BS EN 61008, BS EN 61009.

Manufacturers/suppliers must be able to provide, when requested, relevant documentation proving conformance with standards and legislation (e.g.. declaration of conformity, technical file).

### CHECK 1 – General Quality Indicators

- \* Imperfections in moulded case finish?
- \* Presence of excess material / jagged edges on the outer casing of mouldings?
- \* Visible corrosion of metal components (terminal clamps / screws)?
- \* Is the product CE and/or UKCA marked? (Marking indicates conformity with all applicable European and/or UK legislation)
- \* Illegible, poorly aligned or smudged markings?

One or more of the above quality indicators could indicate a non-conforming product. Products without CE and/or UKCA marking are non-conforming.

### CHECK 2 – Other Factors to Consider

- \* Purchasing Channel – do you know and trust the person / organisation offering you this product?
- \* How does the weight of the product compare to similar products with which you are possibly more familiar? (A lightweight product could indicate the absence of critical components).
- \* Can your supplier provide you with a copy of a Type Test Certificate to prove conformity?
- \* Does the Type Test certificate come from a recognised laboratory / authority?
- \* BS7671 18th Edition states that devices and components installed in assemblies shall only be those declared suitable by the assembly manufacturer. Incompatible devices / assemblies could result in overheating and failure.
- \* Extreme care must be exercised if you are offered previously used circuit protective devices as the service of these devices will be unknown. It is impossible to know the internal condition and protection capability of a used circuit protective device.

# CHECK 3 – Does the product carry all of the required key markings?

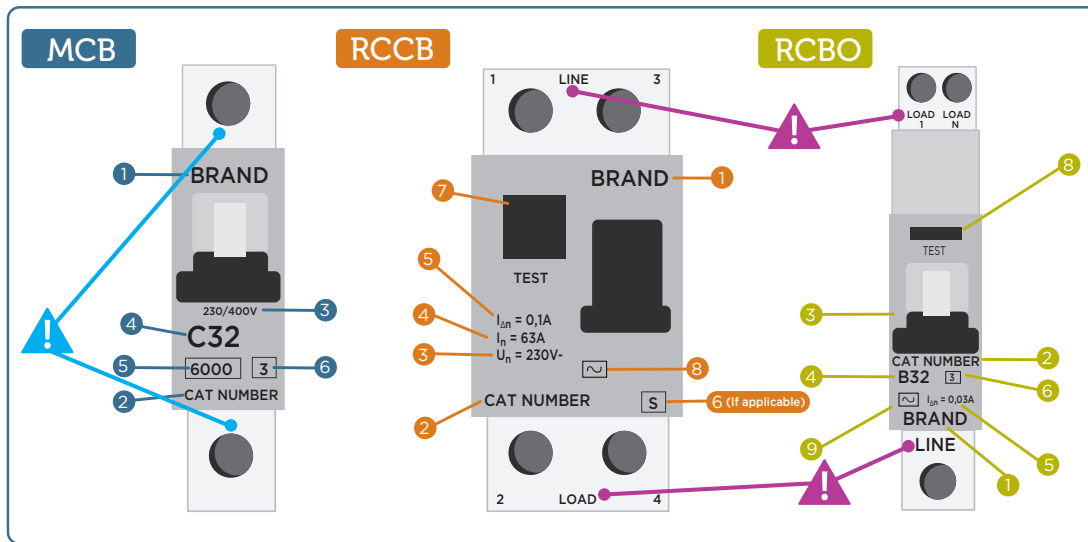

The following must be marked in a durable manner (some may be marked on the side of the device)

## MCB

1. Manufacturer's name or Trade mark.  
Do you know and trust this name?
2. Type, catalogue or serial number
3. Rated voltage(s): 230V or 400V or 230/400V
4. Rated current without the symbol "A", preceded by the symbol of instantaneous tripping (Type B, C or D) e.g. B10, C32, D10
5. Rated short circuit capacity, in Amps within a rectangle (e.g. 6000, 10000)
6. Energy limiting class as shown by the number 1 or 3 in a square

## RCCB

1. Manufacturer's name or Trade mark.  
Do you know and trust this name?
2. Type, catalogue or serial number
3. Rated voltage(s): 230V or 400V or 230/400V
4. Rated current
5. Rated residual operating current ( $I_{\Delta n}$ ) in A or mA
6. The symbol S in a square, for type S (time delay) devices (if applicable)
7. The test button marked with letter T
8. Operating characteristics, AC, A, F or B with the appropriate symbol(s)

## RCBO

1. Manufacturer's name or Trade mark.  
Do you know and trust this name?
2. Type, catalogue or serial number
3. Rated voltage(s): 230V or 400V or 230/400V
4. Rated current without the symbol "A", preceded by the symbol of instantaneous tripping (Type B, C or D) e.g. B10, C32, D10
5. Rated residual operating current ( $I_{\Delta n}$ ) in A or mA
6. Energy limiting class as shown by the number 1 or 3 in a square
7. The symbol S in a square, for type S (time delay) devices (if applicable)
8. The test button marked with letter T
9. Operating characteristics, AC, A, F or B with the appropriate symbol(s)

## RCCBs & RCBOs

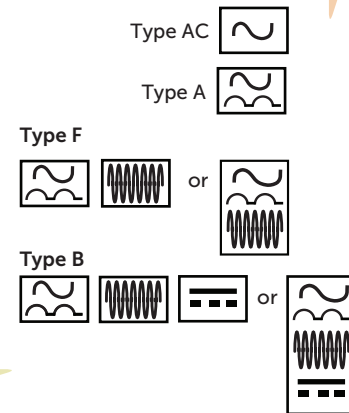

**Unidirectional devices** are protective devices where it is intended by the manufacturer that a source of supply is only connected to one defined set of connection terminals. These devices will be marked 'LINE' and 'LOAD' or 'IN' and 'OUT' or have **directional arrows**. The markings must be followed to avoid the protective function of the device becoming damaged and for compliance with BS 7671 (Regulation 134.1.1).

**Bidirectional devices** are protective devices where it is intended by the manufacturer that a source of supply is connected to **either or both** sets of connection terminals. These devices are readily available for applications where power flow can exist in different directions, such as for Prosumer Installations, Solar PV Systems, Vehicle to Grid, Vehicle to Home or where Battery Storage Systems are used. These devices **will not be marked** 'LINE' and 'LOAD' or 'IN' and 'OUT' or have DIRECTIONAL arrows.

If you have any concerns or suspicions about the authenticity and/or the claims being made in respect of the product, the following courses of action should be considered in order to safeguard your customers and your business.

Ask your supplier for documentary evidence of conformity. Check with relevant test authorities, where appropriate.

Contact BEAMA on 0207 793 3020 or [info@beama.org.uk](mailto:info@beama.org.uk) or visit [beama.org.uk](http://beama.org.uk)